

Perché scegliere Vista BRX

REASONS FOR CHOOSING BRX VISTA

- 01 GELATO A VISTA**
ICE-CREAM ON VIEW
- 02 LA VETRINA CHE FUNGE DA CONSERVATORE**
CON FORTE RISPARMIO DI ENERGIA ELETTRICA
THE DISPLAY CASE THAT ALSO PROVIDES STORAGE, WITH MASSIVE ELECTRICITY SAVINGS
- 03 TRASFORMAZIONE IN VETRINA PASTICCERIA**
CONVERSION TO PASTRY DISPLAY CASE
- 04 POSSIBILITÀ DI ESPORRE PASTICCERIA E MANTENERE IL GELATO SOTTO I COPERCHI**
PASTRY CAN BE DISPLAYED WITH ICE-CREAM IN STORAGE UNDER LIDS
- 05 GELATO ESPOSTO IN CARAPINE DI FORMATI Ø 20 E Ø 26 CM**
Ø 26 PER ESALTARE VISIBILITÀ E Ø 20 PER AUMENTARE IL NUMERO DEI GUSTI
ICE-CREAM DISPLAYED IN CARAPINA PANS OF Ø 20 AND Ø 26 CM,
Ø 26 FOR GREATER VISIBILITY AND Ø 20 TO INCREASE THE NUMBER OF FLAVOURS
- 06 PIÙ GELATO A DISPOSIZIONE GRAZIE ALLA CARAPINA DI RISERVA**
MORE ICE-CREAM AVAILABLE THANKS TO SPARE PAN
- 07 MENO ORE DI LAVORO PER IL GELATIERE, IL GELATO RIMANE IN VETRINA**
LESS WORK REQUIRED AS ICE-CREAM STAYS IN THE DISPLAY CASE
- 08 ALLINEAMENTI PERFETTI FRA GELATERIA, PASTICCERIA, PRALINERIA E CALDO**
PERFECT COMBINATION OF ICE-CREAM, PASTRY, CHOCOLATES AND HEATED FOODS

BANCO POZZETTI A GLICOLE
DOVE IL GELATO SI VEDE
GLYCOL POZZETTI COUNTER WHERE
YOU CAN SEE THE ICE-CREAM



Vetrina VISTA BRX

BRX VISTA DISPLAY CASE

VETRINA VISTA

I banchi tecnologici BRX
possono essere rivestiti
con infinite soluzioni

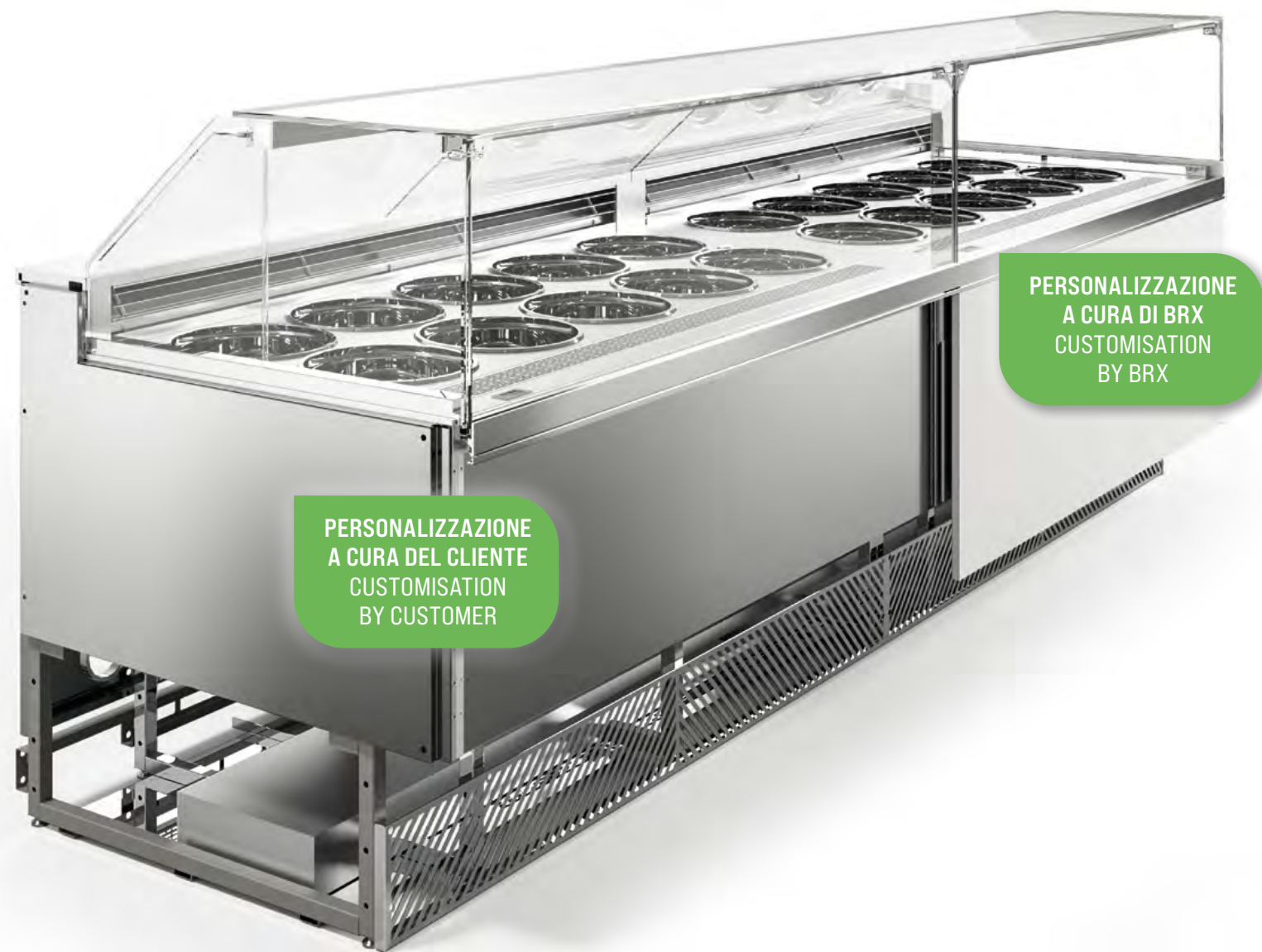

VISTA DISPLAY CASE

BRX high-tech counters
can be customised
in infinite ways



Ad ognuno la sua vetrina

THE RIGHT DISPLAY CASE FOR EVERYONE

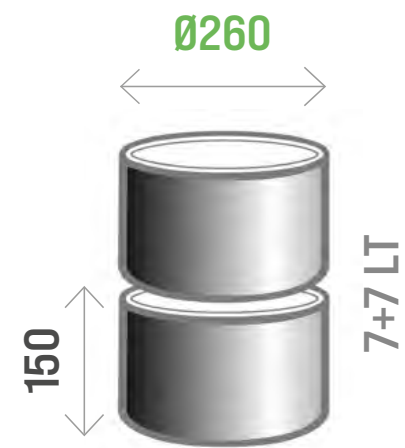

VETRINA A 2 FILE
CON CARAPINE DA Ø26 CM
2-ROW DISPLAY CASE
WITH PANS OF Ø26 CM

Vista è disponibile in moduli da 2 o 3 file, per soddisfare qualsiasi esigenza del cliente. Nella versione a 2 file il gelato è esposto in carapine da 26 cm che ne migliorano la visibilità e ne facilitano l'utilizzo. La versione a 3 file invece, è pensata per chi ha bisogno di avere più gusti da esporre.

Vista is available in 2 or 3-row modules, to meet any customer demands. In the 2-row version, the ice-cream is displayed in pans of 26 cm which improve its visibility and facilitate its use. The 3-row version is intended for users who need to display more flavours.

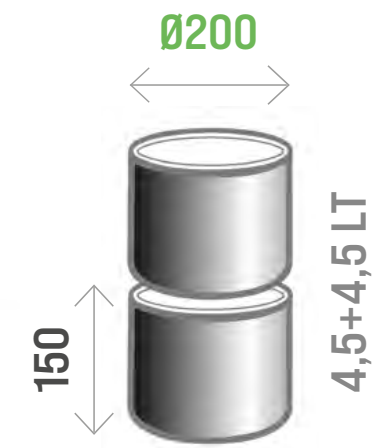

VETRINA A 3 FILE
CON CARAPINE DA Ø20 CM
3-ROW DISPLAY CASE
WITH PANS OF Ø20 CM

Una gamma da 6 a 20 gusti

Vista è disponibile in moduli da 2/3 file per il gelato, in tre altezze diverse: 1150, 1250, 1350 mm.

A range from 6 to 20 flavours

Vista is available in modules of 2/3 rows for ice-cream, in three different heights: 1150, 1250 and 1350 mm.

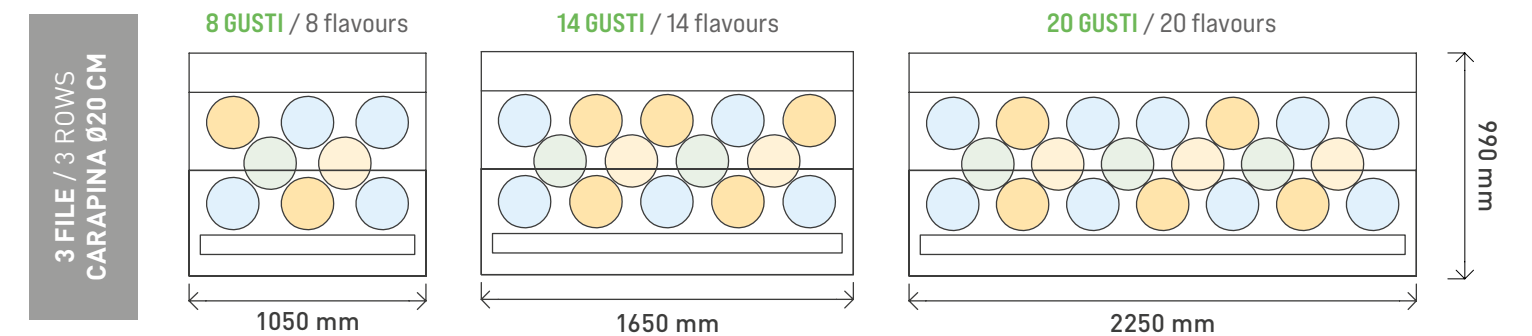
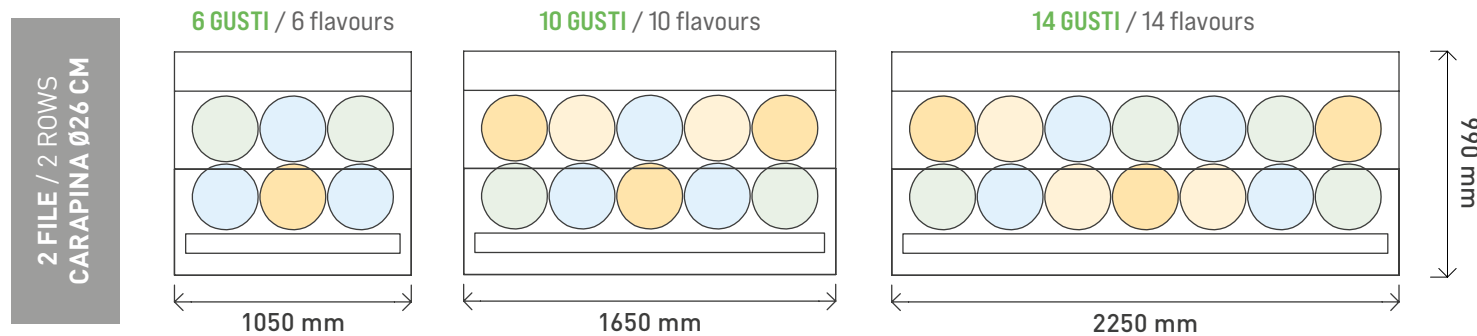

Massima flessibilità di utilizzo

UNBEATABLE OPERATING FLEXIBILITY

1 DOPPIA TECNOLOGIA DI REFRIGERAZIONE

La combinazione tra refrigerazione a glicole e refrigerazione ventilata consente l'utilizzo del banco senza coperchi e di conseguenza il gelato è visibile.

DUAL REFRIGERATION TECHNOLOGY

The combination of glycol and ventilated refrigeration means the counter can be used without lids, with the ice-cream on view.

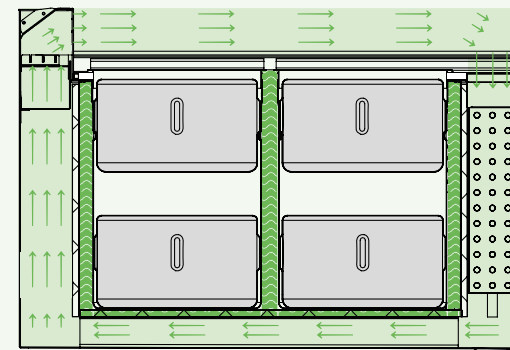

GRANDE RISPARMIO ENERGETICO

grazie alla qualità costruttiva e alla tecnologia innovativa dei banchi a pozzetti glicole BRX
FANTASTIC ENERGY SAVING
 thanks to the construction quality and innovative technology of BRX glycol pozzetti counters

2 TRASFORMABILE FACILMENTE IN BANCO PASTICCERIA

Vista gelato può essere convertita in un banco pasticceria anche nell'arco della stessa giornata, utilizzando gli appositi vassoi espositivi in modalità notte.

EASILY CONVERTS TO PASTRY COUNTER

Ice-cream Vista can be converted into a pastry counter even on the same day, using the special display trays in evening mode.

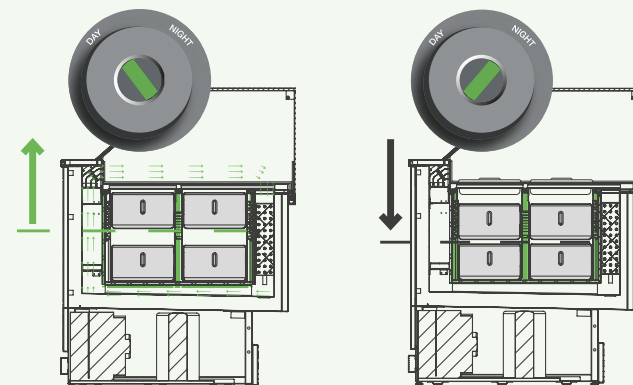

GIORNO / DAY

NOTTE / NIGHT

3 NIENTE PIÙ ARMADI DI CONSERVAZIONE

Grazie a due tecnologie di refrigerazione di giorno l'esposizione è senza coperchi, di notte le carapine si abbassano e si chiudono con coperchio.

NO MORE STORAGE FREEZERS

Thanks to the dual refrigeration technology, ice-cream is displayed without lids; in the evening the pans are lowered and the lids go on.



Giorno
Daytime

Il gelato è visibile
Ice-cream on view



Notte
Nighttime

Il gelato è conservato
all'interno della vetrina
Ice-cream stored
inside display case



Pasticceria
Pastry

Anche con gelato in conservazione
Even with ice-cream stored inside



Gelato e pasticceria
Ice-cream and pastry

Anche serviti contemporaneamente
Even served simultaneously



Banchi Pasticceria/Pralineria

COUNTERS FOR PASTRY/CHOCOLATES



H 115 cm



H 125 cm
1 Mensola (non refrigerata)
1 Shelf (not refrigerated)



H 135 cm
2 Mensole (non refrigerate)
2 Shelves (not refrigerated)

Vista è anche pasticceria e pralineria

Vista non è solo vetrina gelato, ma è disponibile anche nei seguenti servizi:

- Pasticceria Ventilata
- Doppia Funzione (Pasticceria/Pralineria)
- Doppia Funzione (Pasticceria/Caldo Secco)
- Caldo Secco

Vista is also available for pastries and chocolate

Not just an ice-cream display case, Vista can also provide the following functions:

- Ventilated Pastry
- Dual Function (Pastry/Chocolates)
- Dual Function (Pastry/Dry Heated)
- Dry Heated

TUTTI I MODULI VISTA SONO DISPONIBILI IN TRE ALTEZZE: 1150, 1250 E 1350 MM

ALL VISTA MODULES ARE AVAILABLE IN THREE HEIGHTS: 1150, 1250 AND 1350 MM

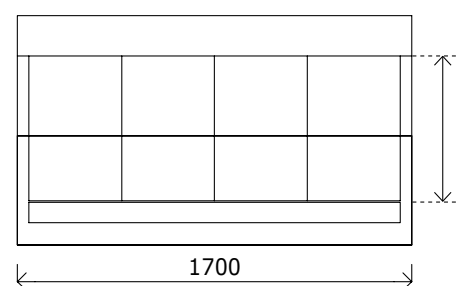
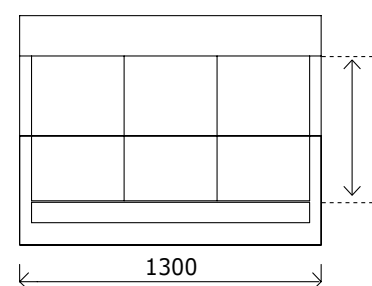
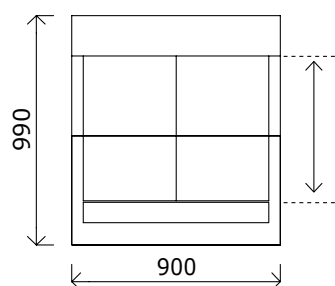

Banchi Pasticceria/Pralineria Canalizzati

COUNTERS FOR PASTRY/CHOCOLATES IN-LINE



H 115 cm



H 125 cm
1 Mensola (non refrigerata)
1 Shelf (not refrigerated)



H 135 cm
2 Mensole (non refrigerate)
2 Shelves (not refrigerated)

Tante configurazioni per il tuo spazio

Vista è disponibile in moduli da 900/1300/1700/2100 mm and corner.

Large choice of configurations to suit your space

Vista is available in modules of 900/1300/1700/2100 mm and corner.

TUTTI I MODULI VISTA GELATERIA PASTICCERIA E PRALINERIA POSSONO ESSERE CANALIZZATI

ALL VISTA PASTRY AND CHOCOLATE MODULES ARE SUITABLE FOR IN-LINE INSTALLATION

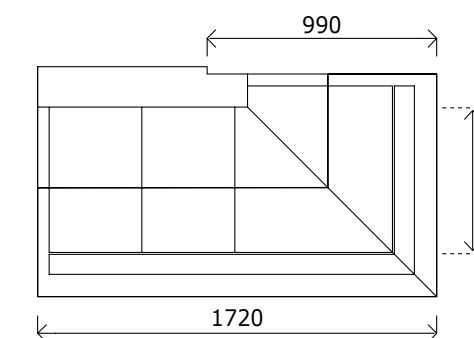
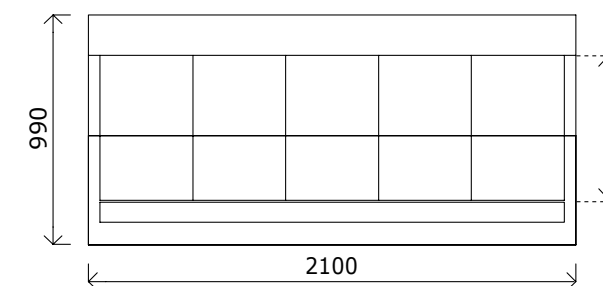

BRX

POZZETTI GELATO & BAR TECHNOLOGY

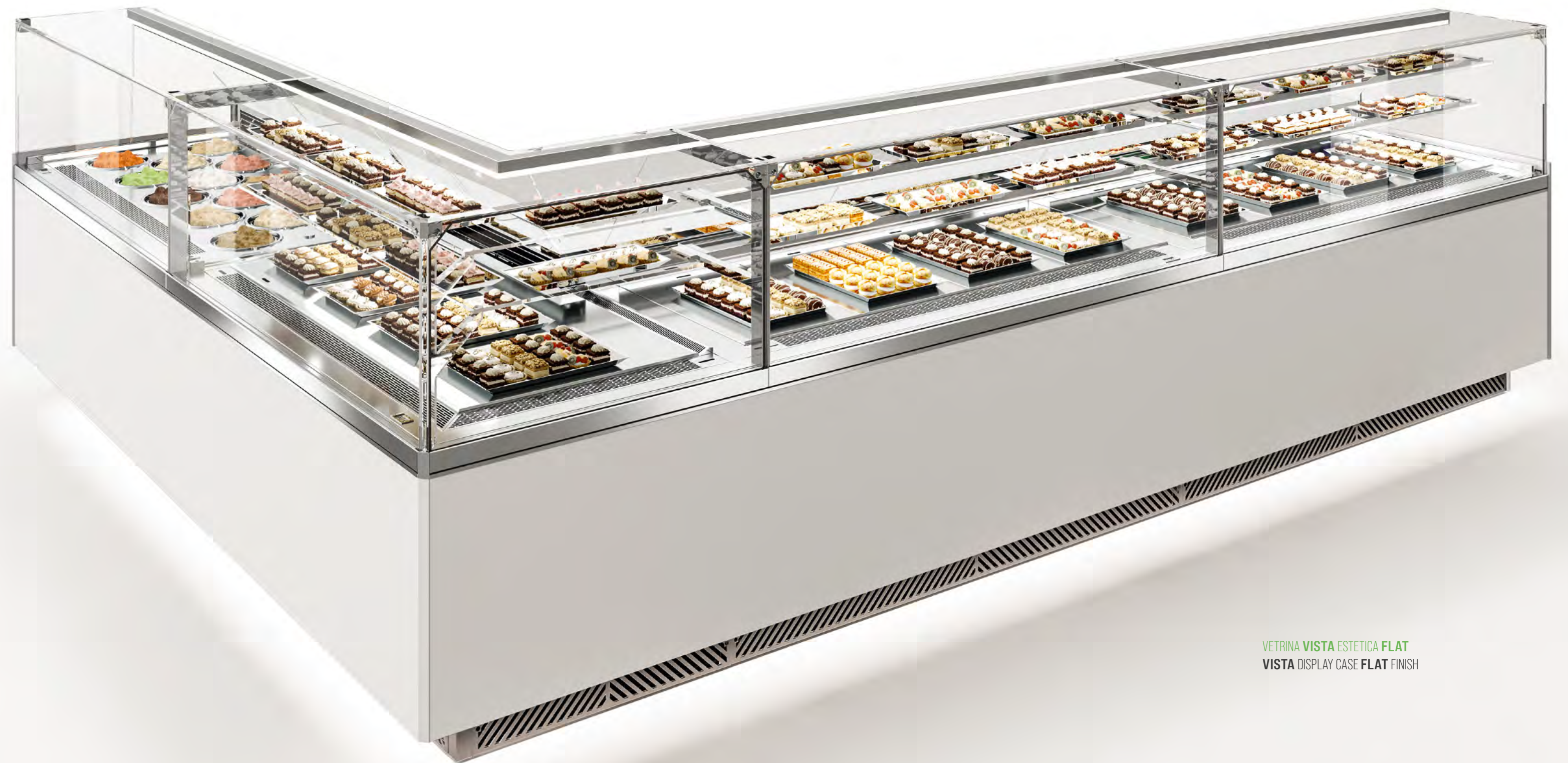

VETRINA **VISTA** ESTETICA **FLAT**
VISTA DISPLAY CASE **FLAT** FINISH

VISTA Sezioni e piante

VISTA CROSS-SECTIONS AND FLOOR PLANS

GELATERIE 2 FILE DIAMETRO 26
ICE-CREAM 2 ROWS DIAMETER 26

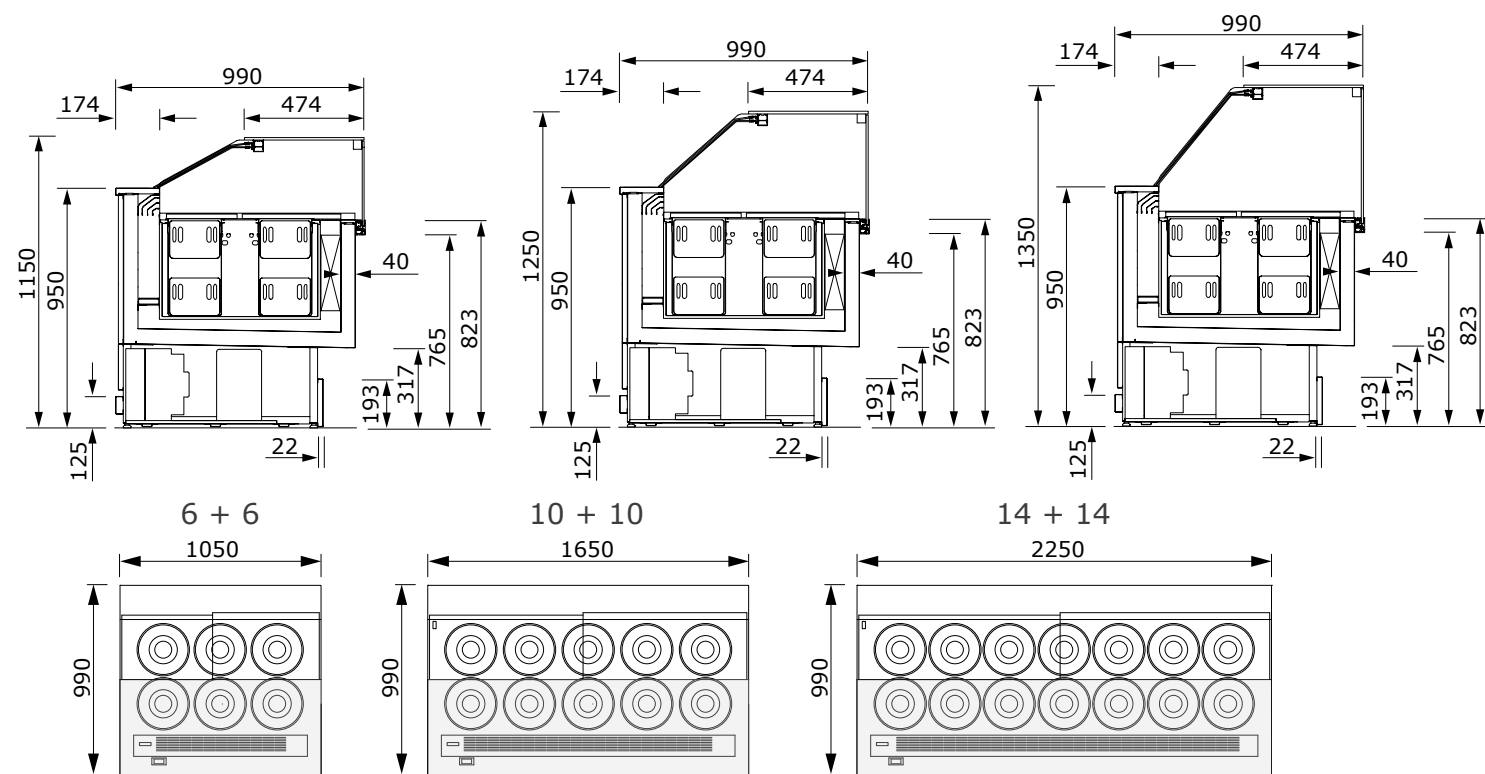

VISTA Sezioni e piante

VISTA CROSS-SECTIONS AND FLOOR PLANS

TORTE GELATO / SEMIFREDDI / STECCHI GELATO
ICE-CREAM CAKES / REFRIGERATED GATEAU / ICE LOLLIES

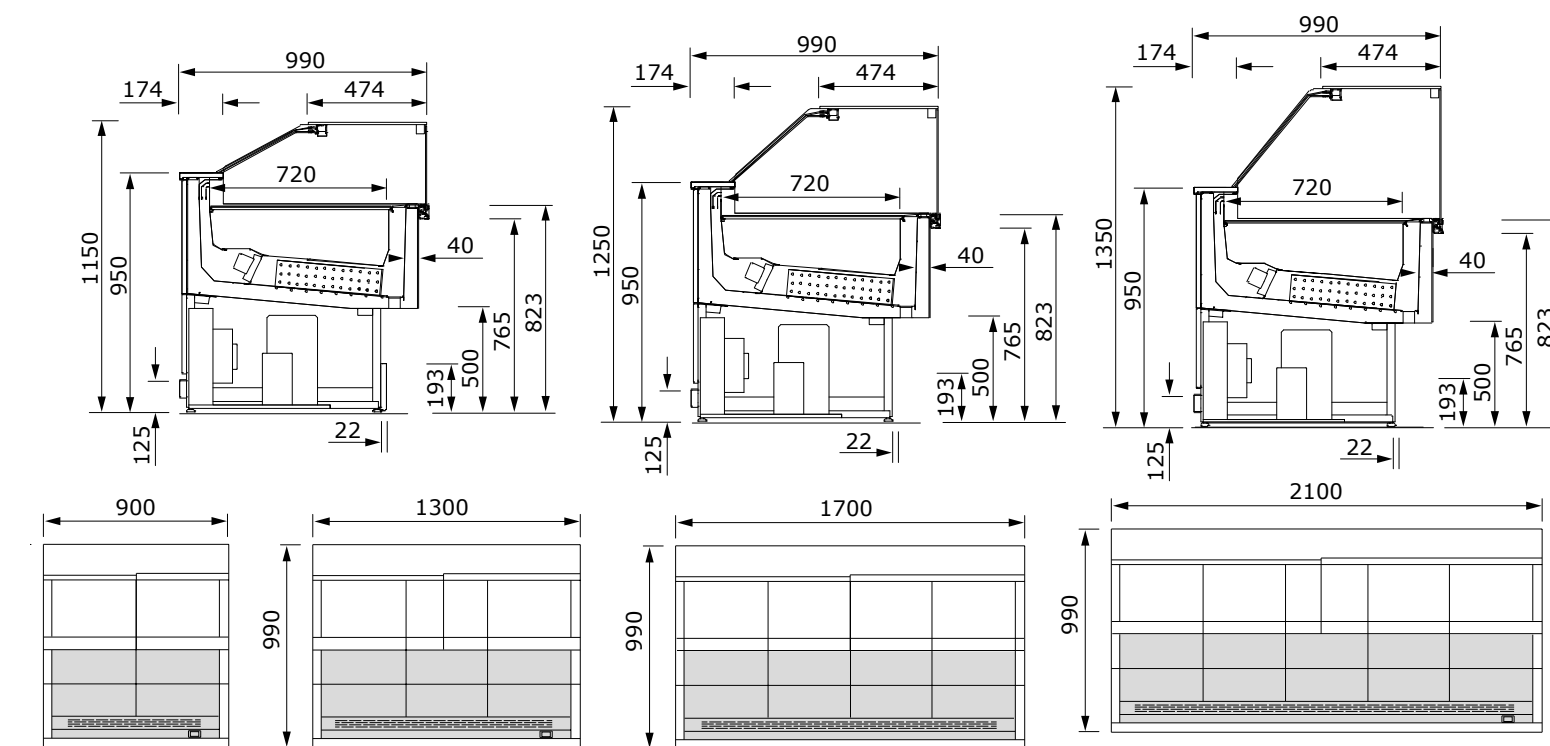

GELATERIE 3 FILE DIAMETRO 20
ICE-CREAM 3 ROWS DIAMETER 20

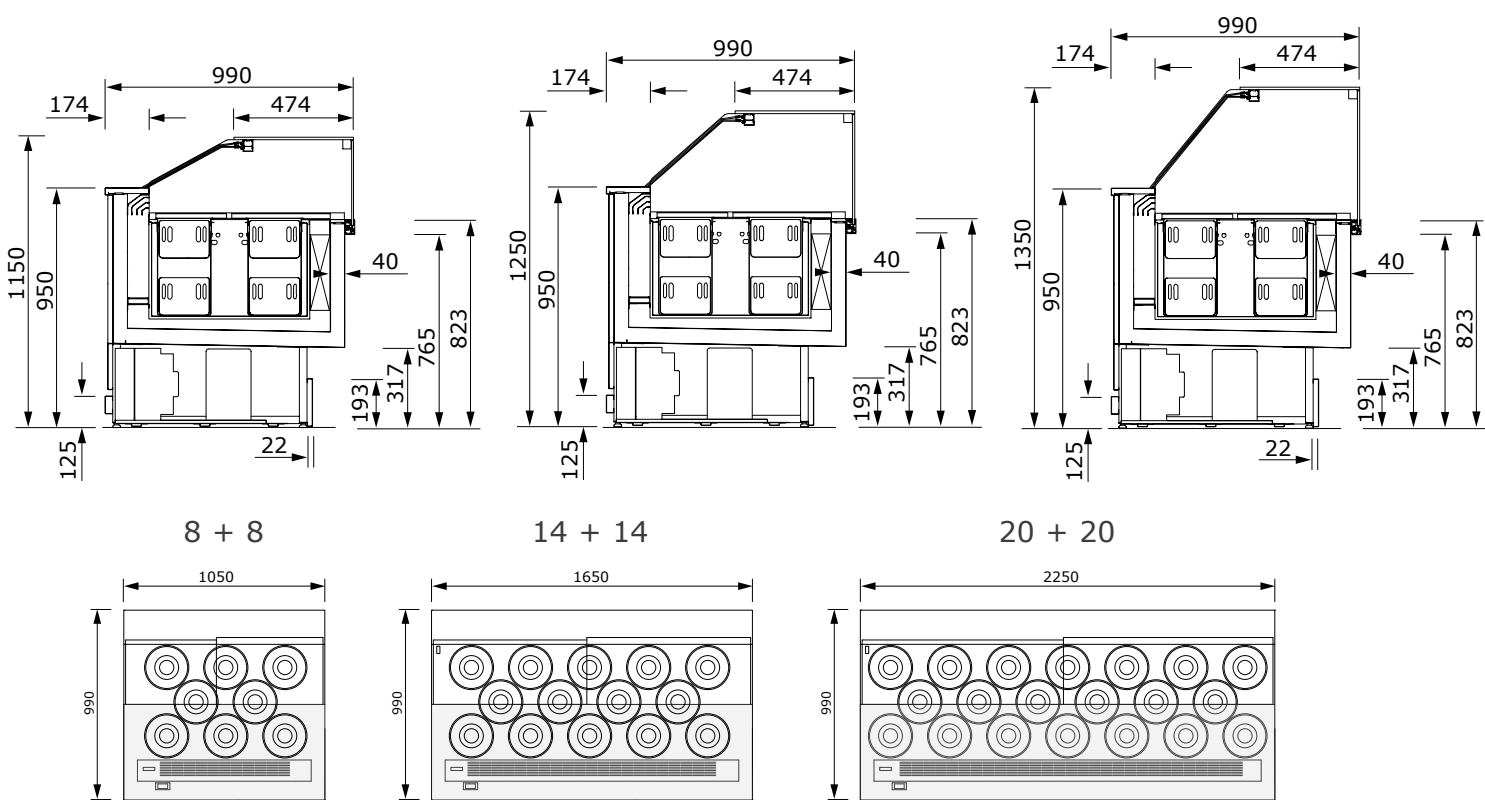

VISTA Sezioni e piante

VISTA CROSS-SECTIONS AND FLOOR PLANS

REFRIGERAZIONE VENTILATA VENTILATED REFRIGERATION

DF PASTICCERIA VENTILATA + PRALINERIA DF VENTILATED PASTRY + CHOCOLATES

DF PASTICCERIA VENTILATA + CALDO SECCO DF VENTILATED PASTRY + DRY HEATED

SENZA CELLA DI RISERVA - WITHOUT STORAGE CELL

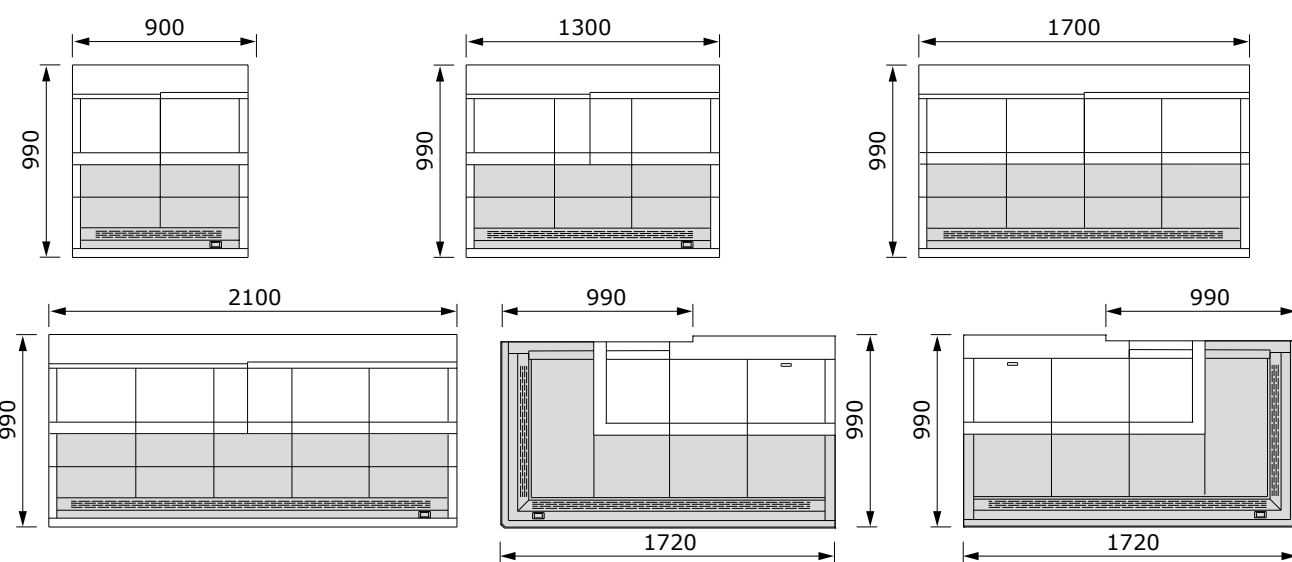
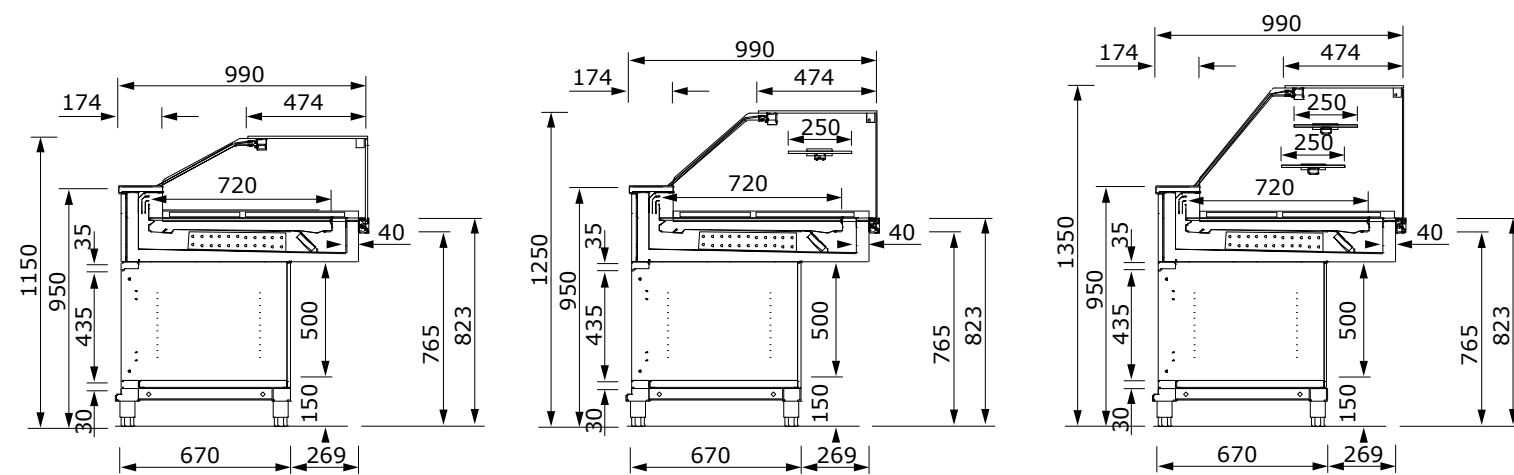

VISTA Sezioni e piante

VISTA CROSS-SECTIONS AND FLOOR PLANS

REFRIGERAZIONE VENTILATA VENTILATED REFRIGERATION

DF PASTICCERIA VENTILATA + PRALINERIA DF VENTILATED PASTRY + CHOCOLATES

DF PASTICCERIA VENTILATA + CALDO SECCO DF VENTILATED PASTRY + DRY HEATED

CON CELLA DI RISERVA - WITH STORAGE CELL

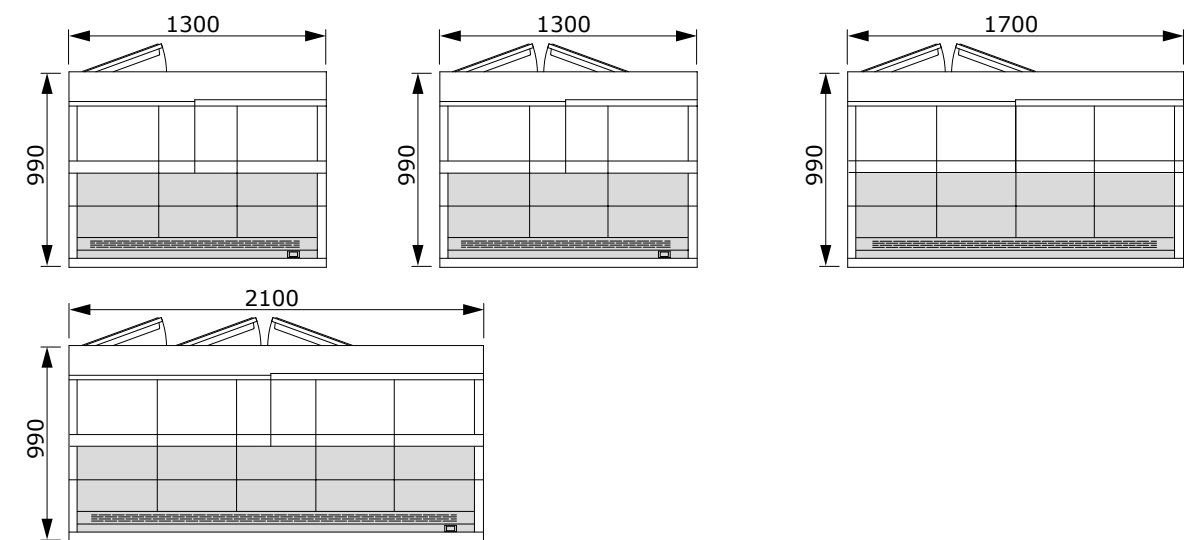
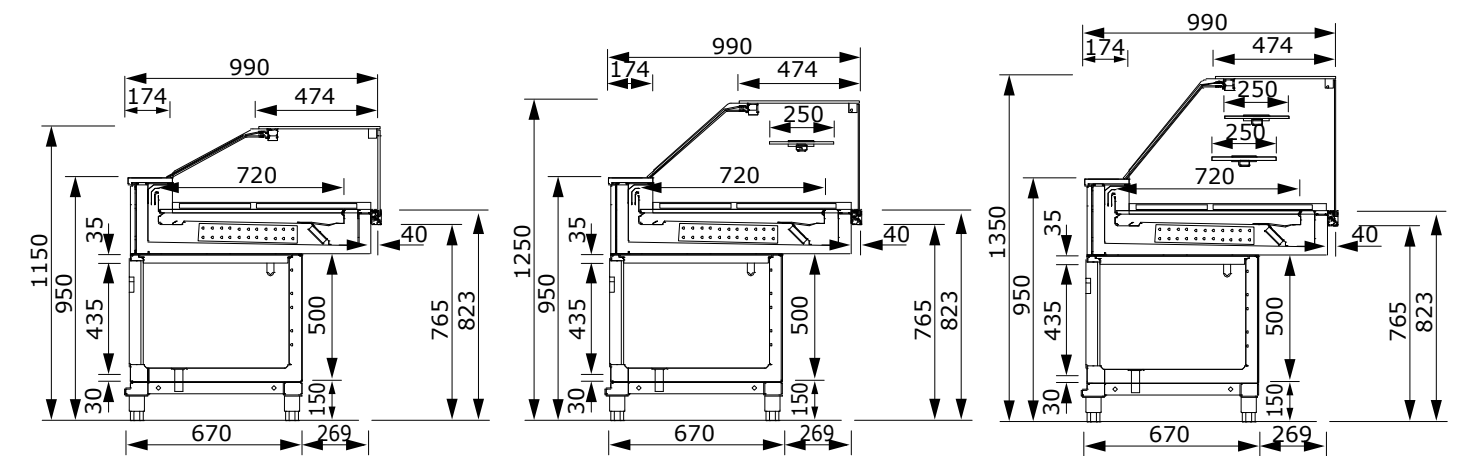

BASAMENTO STAND

A GIORNO OPEN

CON CELLA DI RISERVA REFRIGERATA
WITH REFRIGERATED STORAGE CELL



VISTA Sezioni e piante

VISTA CROSS-SECTIONS AND FLOOR PLANS

CALDO SECCO DRY HEATED
CALDO SECCO UMIDO DRY HEATED / HUMID
PANE BREAD

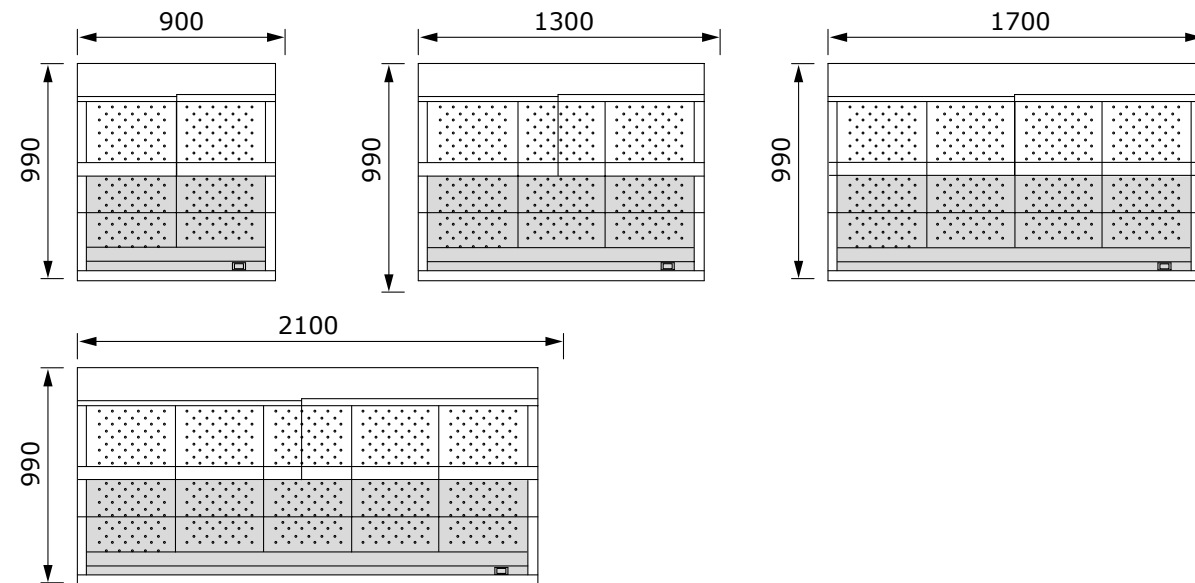
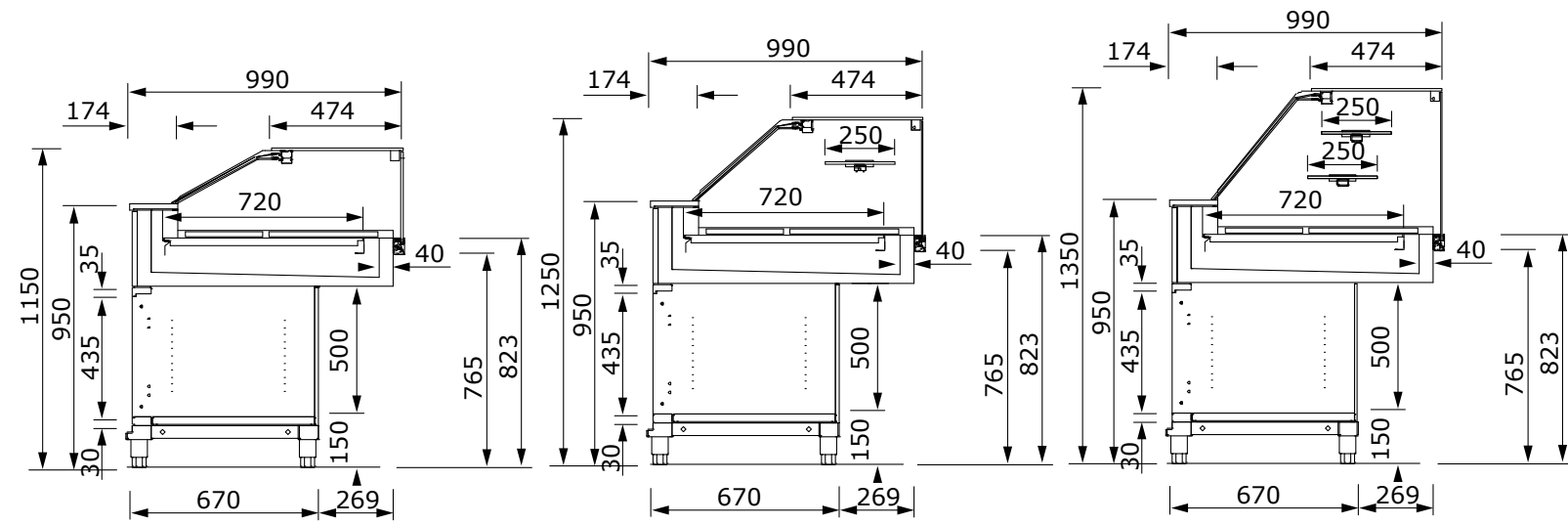



Vetrina VISTA EXTREME BRX

BRX VISTA EXTREME DISPLAY CASE

Perché scegliere Vista Extreme BRX

REASONS FOR CHOOSING BRX VISTA EXTREME

- 01 PROFONDITÀ 85 CM**
DEPTH 85 CM
- 02 GELATO A VISTA**
ICE-CREAM ON VIEW
- 03 LA VETRINA CHE FUNGE DA CONSERVATORE**
CON ELEVATO RISPARMIO DI ENERGIA ELETTRICA
THE DISPLAY CASE THAT ALSO PROVIDES STORAGE, WITH MASSIVE ELECTRICITY SAVINGS
- 04 TRASFORMAZIONE IN VETRINA PASTICCERIA**
CONVERSION TO PASTRY DISPLAY CASE
- 05 POSSIBILITÀ DI ESPORRE PASTICCERIA E MANTENERE IL GELATO SOTTO I COPERCHI**
PASTRY CAN BE DISPLAYED WITH ICE-CREAM IN STORAGE UNDER LIDS
- 06 GELATO ESPOSTO IN CARAPINE CILINDRICHE DI 20 CM**
ICE-CREAM DISPLAYED IN CYLINDRICAL CARAPINA PANS OF 20 CM
- 07 PIÙ GELATO A DISPOSIZIONE GRAZIE ALLA CARAPINA DI RISERVA**
MORE ICE-CREAM AVAILABLE THANKS TO SPARE PAN
- 08 MENO ORE DI LAVORO PER IL GELATIERE, IL GELATO RIMANE IN VETRINA**
LESS WORK REQUIRED AS ICE-CREAM STAYS IN THE DISPLAY CASE
- 09 ALLINEAMENTI PERFETTI FRA GELATERIA, PASTICCERIA, PRALINERIA E CALDO SECCO**
PERFECT COMBINATION OF ICE-CREAM, PASTRY, CHOCOLATES AND DRY HEAT

BRX

VETRINA VISTA EXTREME

I banchi tecnologici BRX
possono essere rivestiti
con infinite soluzioni



VISTA EXTREME DISPLAY UNIT

BRX high-tech counters
can be customised
in infinite ways



Vista Extreme

Il banco pozzetti a glicole dove
il gelato si vede,
in soli 85cm

VISTA EXTREME
THE GLYCOL POZZETTI COUNTER
WHERE YOU CAN SEE THE ICE-CREAM,
IN JUST 85CM



GRANDE RISPARMIO ENERGETICO
grazie alla qualità costruttiva e alla tecnologia
innovativa dei banchi a pozzetti glicole BRX
FANTASTIC ENERGY SAVING
thanks to the construction quality and innovative
technology of BRX glycol pozzetti counters

FINO AL 70% IN MENO
DI ENERGIA ELETTRICA CONSUMATA
UP TO 70% LESS
ELECTRICITY USE



NOVITÀ
NEW

VETRINA **VISTA EXTREME**
ESTETICA **EMOTION**
VISTA EXTREME DISPLAY CASE
EMOTION FINISH

Vista Extreme



GRANDE RISPARMIO ENERGETICO
 grazie alla qualità costruttiva e alla tecnologia
 innovativa dei banchi a pozzetti glicole BRX

FANTASTIC ENERGY SAVING
 thanks to the construction quality and innovative
 technology of BRX glycol pozzetti counters



VETRINA **VISTA EXTREME**
 ESTETICA **FLAT**
VISTA EXTREME DISPLAY CASE
FLAT FINISH

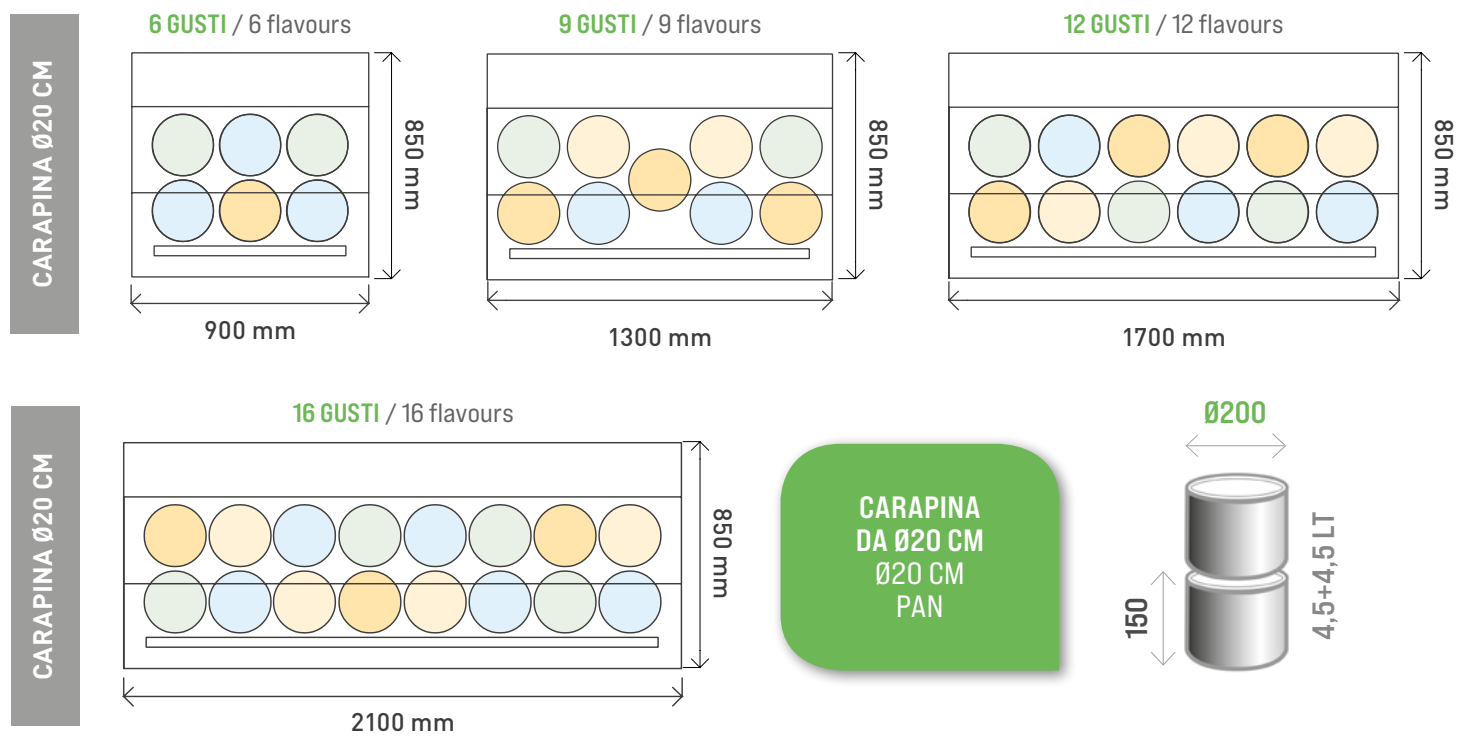

Una gamma da 6 a 16 gusti

Vista Extreme è disponibile in due altezze diverse: 1250 e 1350 mm.

A range from 6 to 16 flavours

Vista Extreme is available in two different heights: 1250 and 1350 mm

Massima flessibilità di utilizzo

UNBEATABLE OPERATING FLEXIBILITY

1 DOPPIA TECNOLOGIA DI REFRIGERAZIONE

La combinazione tra refrigerazione a glicole e refrigerazione ventilata consente l'utilizzo del banco senza coperchi e di conseguenza il gelato è visibile.

DUAL REFRIGERATION TECHNOLOGY

The combination of glycol and ventilated refrigeration means the counter can be used without lids, with the ice-cream on view.

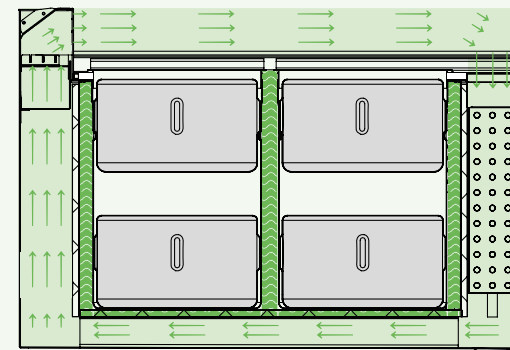

GRANDE RISPARMIO ENERGETICO

grazie alla qualità costruttiva e alla tecnologia innovativa dei banchi a pozzetti glicole BRX
FANTASTIC ENERGY SAVING
 thanks to the construction quality and innovative technology of BRX glycol pozzetti counters

2 TRASFORMABILE FACILMENTE IN BANCO PASTICCERIA

Vista gelato può essere convertita in un banco pasticceria anche nell'arco della stessa giornata, utilizzando gli appositi vassoi espositivi in modalità notte.

EASILY CONVERTS TO PASTRY COUNTER

Ice-cream Vista can be converted into a pastry counter even on the same day, using the special display trays in evening mode.

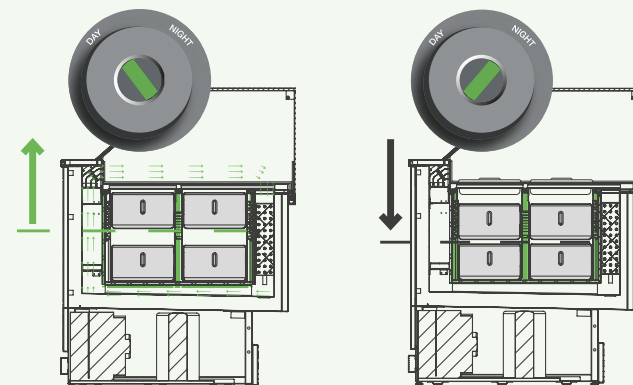

GIORNO / DAY

NOTTE / NIGHT

3 NIENTE PIÙ ARMADI DI CONSERVAZIONE

Grazie a due tecnologie di refrigerazione di giorno l'esposizione è senza coperchi, di notte le carapine si abbassano e si chiudono con coperchio.

NO MORE STORAGE FREEZERS

Thanks to the dual refrigeration technology, ice-cream is displayed without lids; in the evening the pans are lowered and the lids go on.



Giorno
Daytime

Il gelato è visibile
Ice-cream on view



Notte
Nighttime

Il gelato è conservato all'interno della vetrina
Ice-cream stored inside display case



Pasticceria
Pastry

Anche con gelato in conservazione
Even with ice-cream stored inside



Gelato e pasticceria
Ice-cream and pastry

Anche serviti contemporaneamente
Even served simultaneously



VISTA EXTREME PASTICCERIA VISTA EXTREME PASTRY



2 Mensole (non refrigerate)
2 Shelves (not refrigerated)

VETRINA VISTA EXTREME ESTETICA EMOTION
VISTA EXTREME DISPLAY CASE EMOTION FINISH



VISTA EXTREME PASTICCERIA VISTA EXTREME PASTRY



2 Mensole (non refrigerate)
2 Shelves (not refrigerated)

VETRINA VISTA EXTREME ESTETICA PLANK
VISTA EXTREME DISPLAY CASE PLANK FINISH



85 CM
1 Mensola (non refrigerata)
1 Shelf (not refrigerated)



85 CM
2 Mensole (non refrigerate)
2 Shelves (not refrigerated)

VISTA EXTREME Sezioni e piante

VISTA EXTREME CROSS-SECTIONS AND FLOOR PLANS

GELATERIE 2 FILE DIAMETRO 20
ICE-CREAM 2 ROWS DIAMETER 20

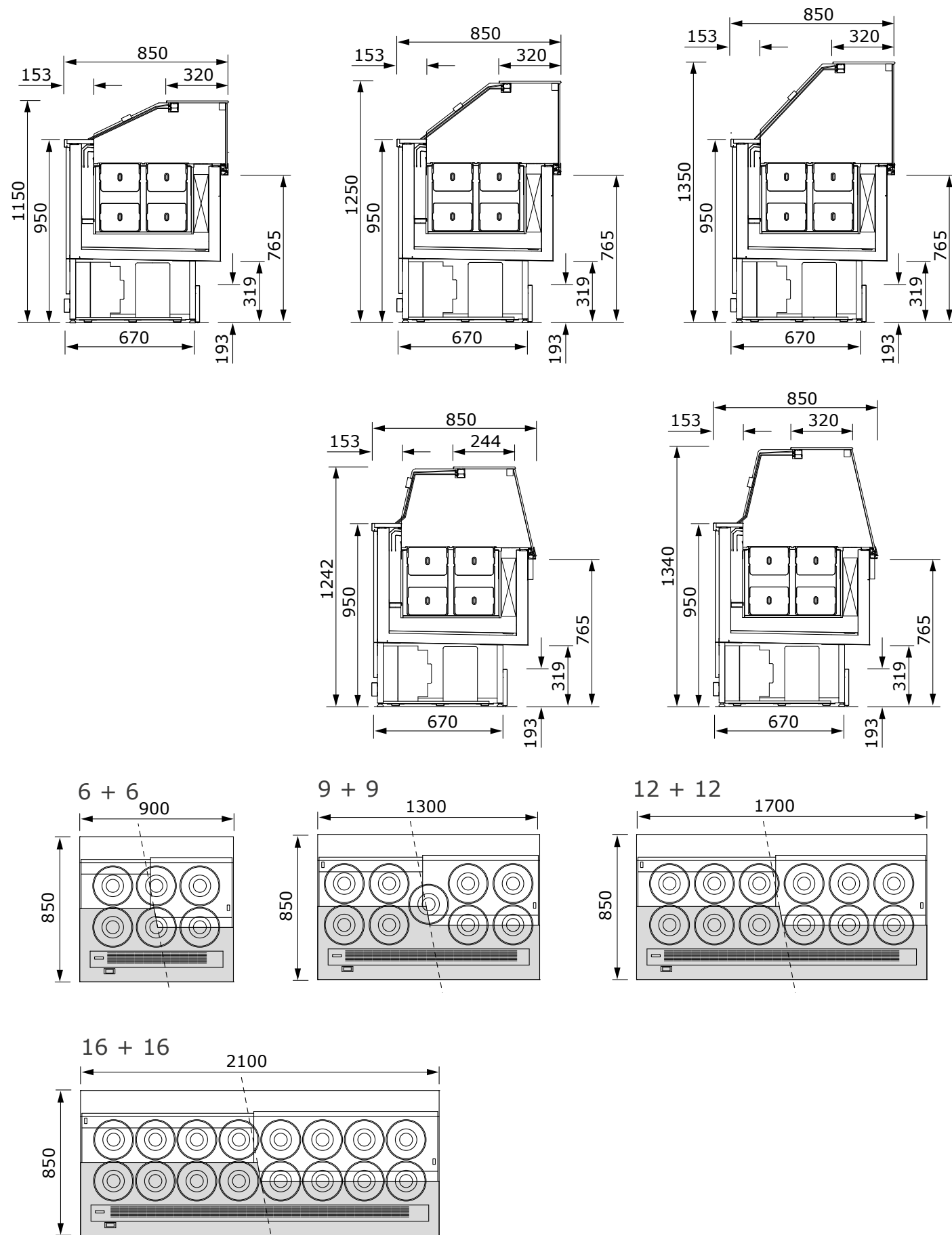

VISTA EXTREME Sezioni e piante

VISTA EXTREME CROSS-SECTIONS AND FLOOR PLANS

TORTE GELATO / SEMIFREDDI / STECCHI GELATO
ICE-CREAM CAKES / REFRIGERATED GATEAU / ICE LOLLIES

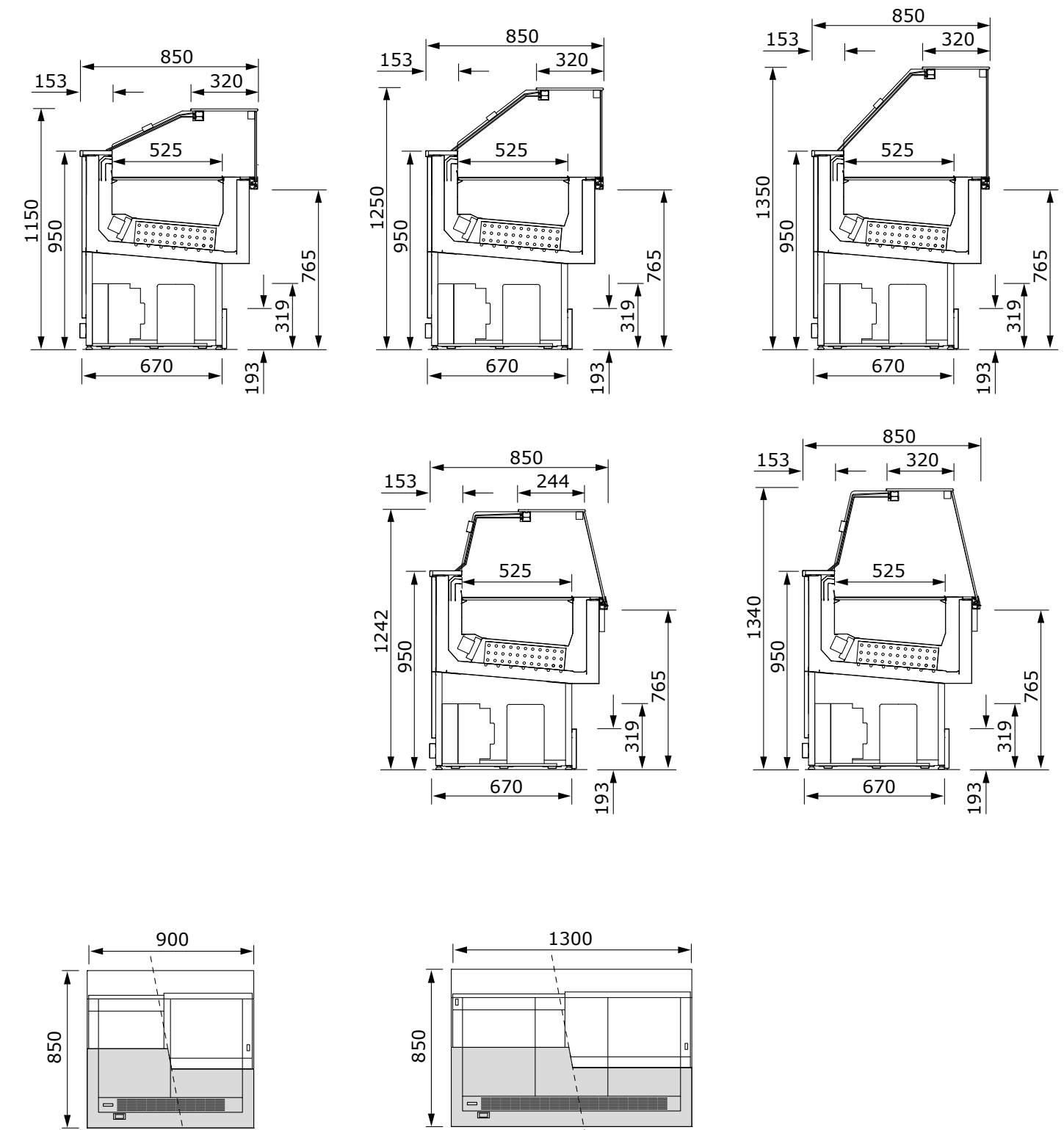

VISTA EXTREME Sezioni e piante

VISTA EXTREME CROSS-SECTIONS AND FLOOR PLANS

REFRIGERAZIONE VENTILATA VENTILATED REFRIGERATION

DF PASTICCERIA VENTILATA + PRALINERIA DF VENTILATED PASTRY + CHOCOLATES

DF PASTICCERIA VENTILATA + CALDO SECCO DF VENTILATED PASTRY + DRY HEATED

SENZA CELLA DI RISERVA - WITHOUT STORAGE CELL

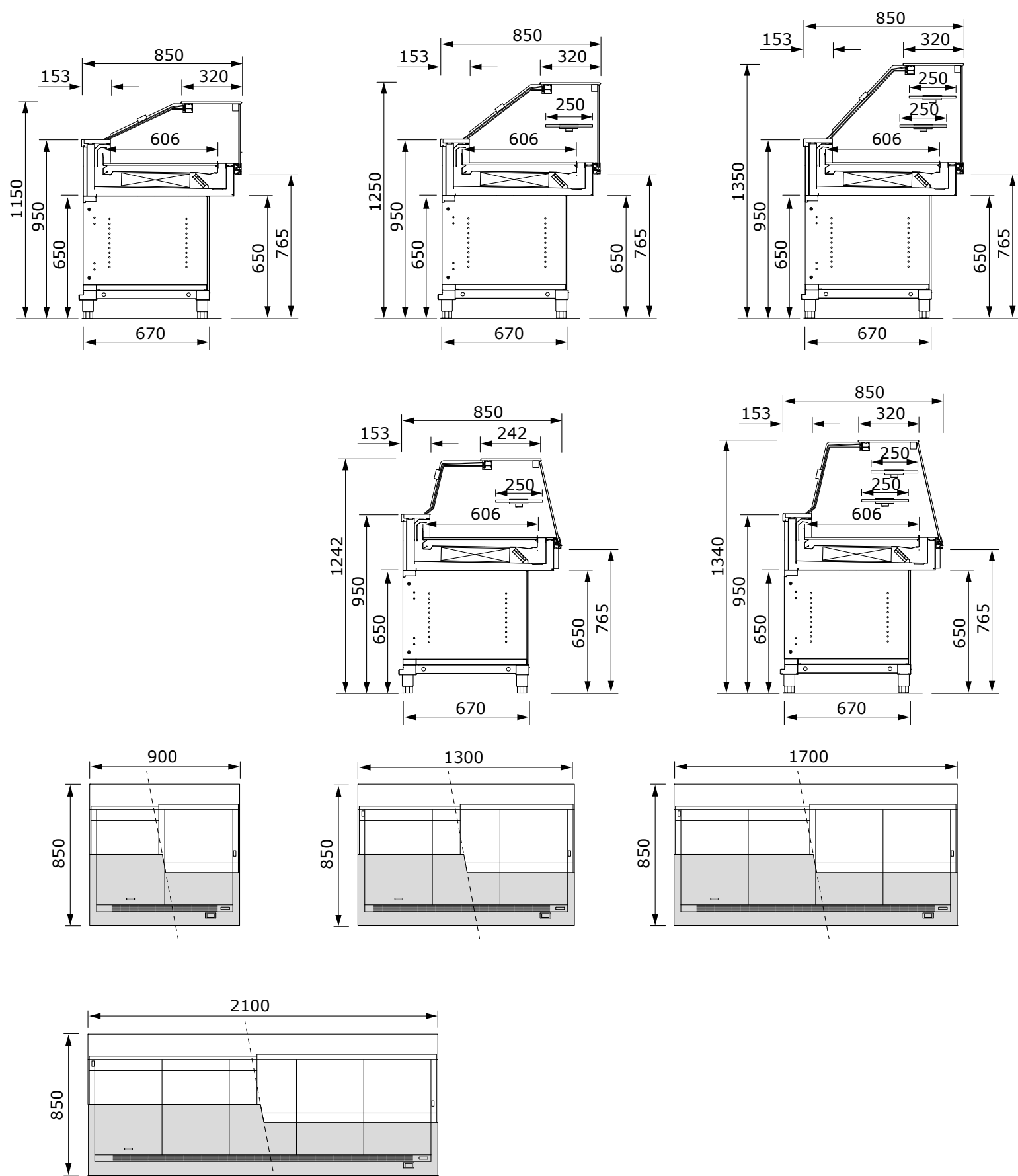

VISTA EXTREME Sezioni e piante

VISTA EXTREME CROSS-SECTIONS AND FLOOR PLANS

REFRIGERAZIONE VENTILATA VENTILATED REFRIGERATION

DF PASTICCERIA VENTILATA + PRALINERIA DF VENTILATED PASTRY + CHOCOLATES

DF PASTICCERIA VENTILATA + CALDO SECCO DF VENTILATED PASTRY + DRY HEATED

SENZA CELLA DI RISERVA - WITH REFRIGERATED CELL

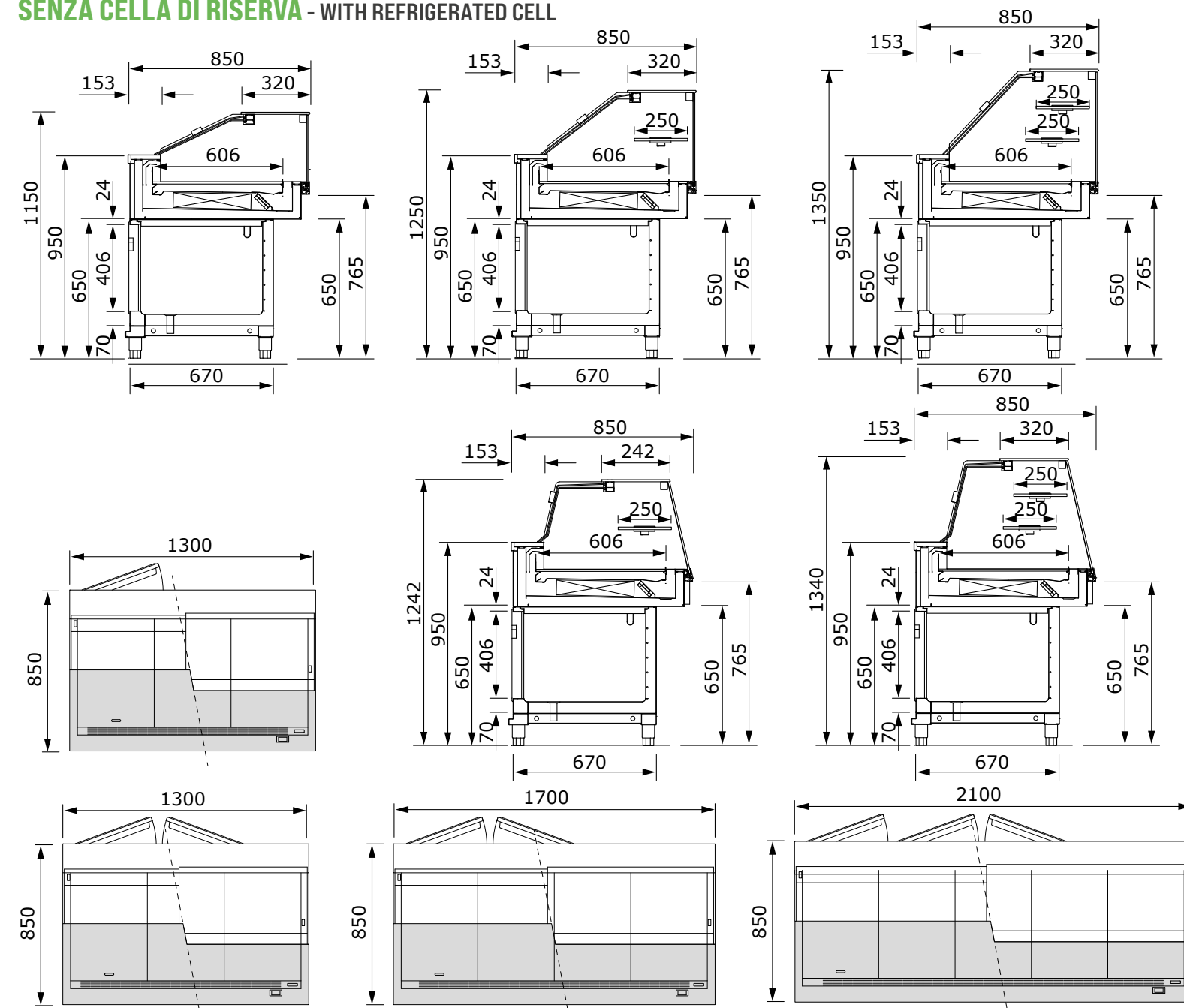

BASAMENTO STAND

A GIORNO OPEN

CON CELLA DI RISERVA REFRIGERATA
WITH REFRIGERATED STORAGE CELL



VISTA EXTREME Sezioni e piante

VISTA EXTREME CROSS-SECTIONS AND FLOOR PLANS

CALDO SECCO DRY HEATED

CALDO SECCO UMIDO DRY HEATED / HUMID

PANE BREAD

