

DeBlasi

Starlet

# Starlet

Starlet significa approccio giovane, appeal perfettamente allineato a qualsiasi filosofia di arredamento. Vetrina affascinante e intelligente per un uso trasversale, contemporaneo ed essenziale per pasticceria, gelateria, pralineria, tavola calda. Ideale per prime attività, per ambienti informali, giocosi e colorati, in situazioni minimali o in ambienti classici ed eleganti.

Starlet model means a flexible and new approach to any furnishing philosophy. Smart and charming showcase line to be used in different situations, ranging from contemporary and essential pastry shops to ice cream parlours; from confectioneries to hot snack deli shops. It is ideal both for a start up and for informal and colorful places, or for classic and elegant ambience as well.



DeBlasi

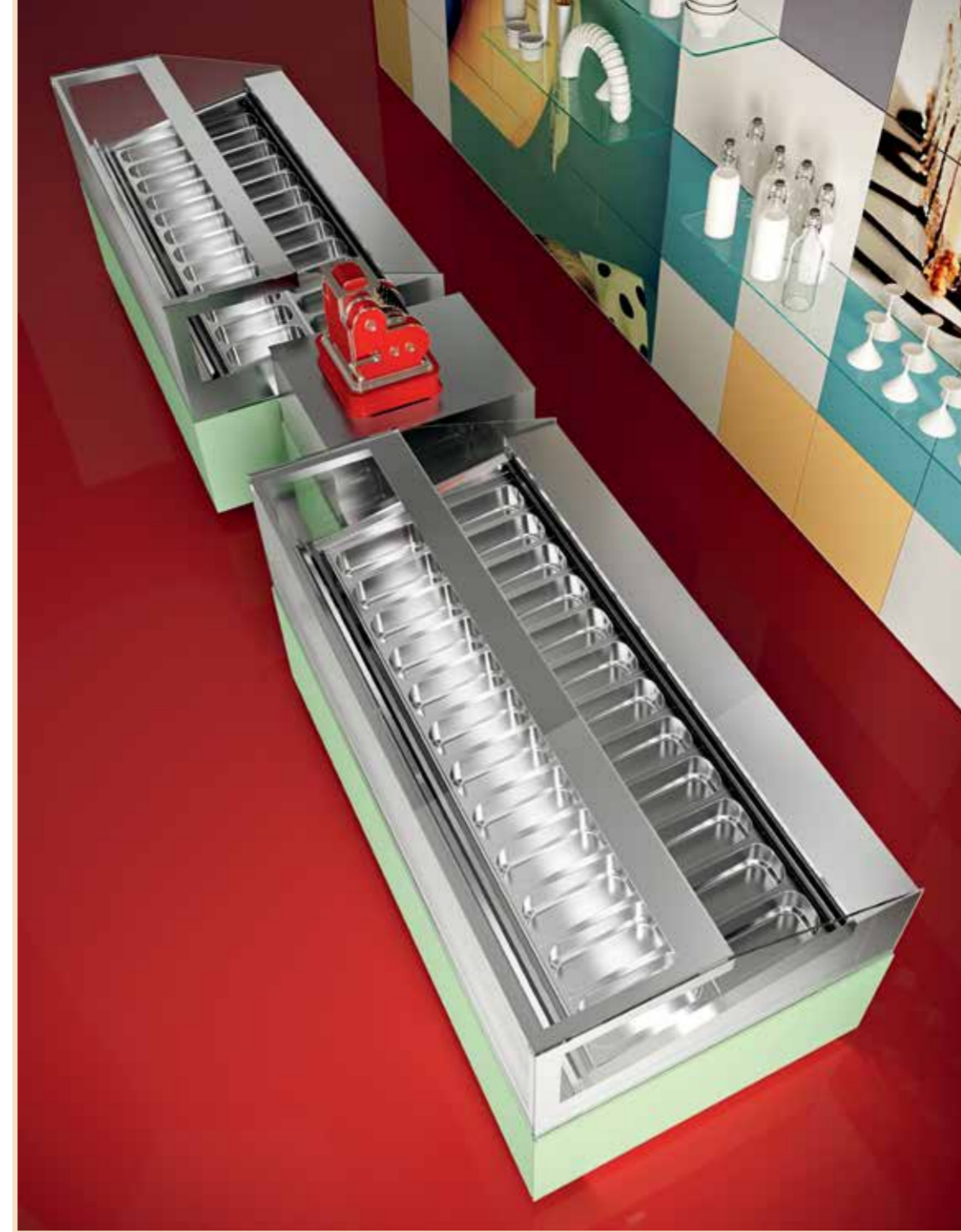



Starlet

# Starlet





# Starlet

**Pasticceria, gelateria.** Pannellatura vetrina e cassa in laccato RAL 5024.  
**Retrobanco.** Sistema espositivo Metrika (Logika); elemento murale a mikrodoga (passo 16) in finitura rovere.  
**Pastry and gelato showcase.** Lacquered RAL 5024 front paneling for display case and cash counter.  
**Back counter.** Metrika system by Logika. Slatted wall element oak finishing.







**Pralineria, pasticceria.** Pannellatura vetrina e cassa in laccato bianco.  
**Retrobanco.** Sistema espositivo Evoka (Logika) in opaco bianco.  
Confectionery and pastry showcase. White lacquered front paneling  
for display case and cash counter.  
Back counter. Evoka system by Logika, matt white finishing.



Starlet

CARATTERISTICHE TECNICHE. TECHNICAL FEATURES.

gelateria  
ice-cream

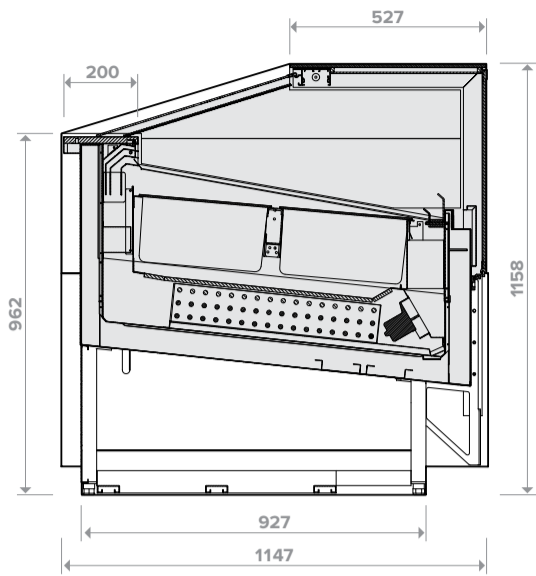

vaschette per gelateria 16,5 x 36 cm \_ pans for ice-cream 16,5 x 36 cm

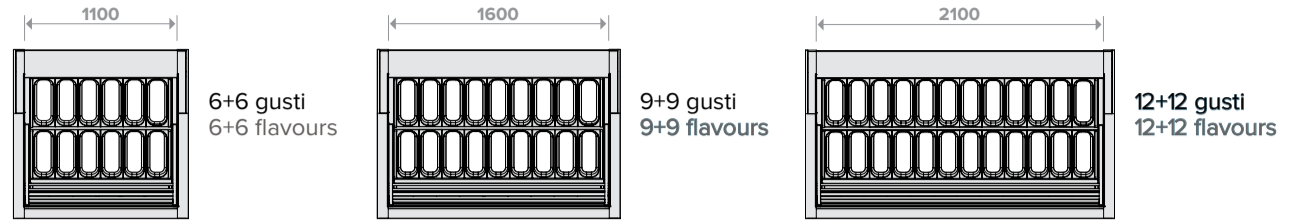

vaschette per gelateria 25 x 36 cm \_ pans for ice-cream 25 x 36 cm

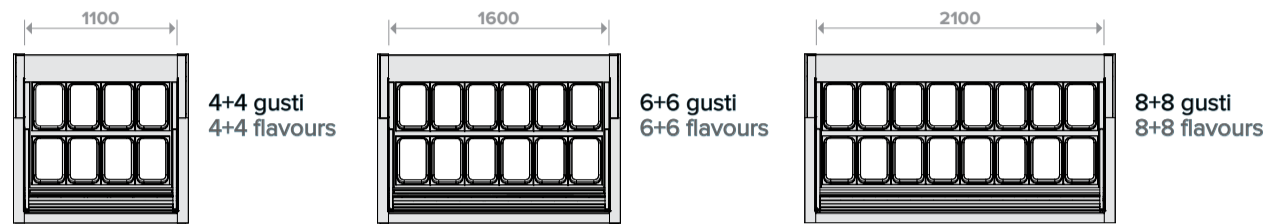

pasticcera  
pastry

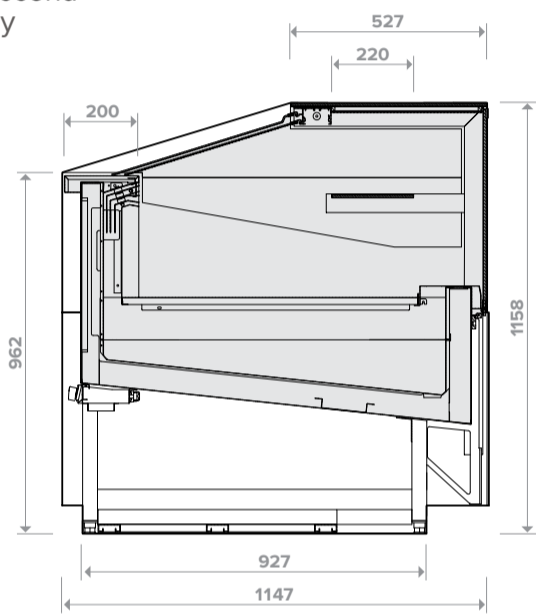

pralineria  
chocolate



tavola calda secca  
dry heat cabinet



	modello	dimensioni (L)*	mandata (con UR esterna 10m)	aspirazione (con UR esterna 10m)	n° vaschette standard 5 lt. (360X165 mm)	temperatura di esercizio (°c)	tensione/ frequenza	resa (w)	potenza assorbita (W) UI	peso netto (Kg)
	type	dimensions (W)*	delivery (Compressor 15m)	suction (Compressor 15m)	pan capacity 5 liter (360X165 mm)	working temperature (c°)	voltage/ frequency	resa (w)	absorbed power (W)	net weight (Kg)
gelateria ice-cream	STARLET 12	mm 1100	12	16	12	-14 -18	230/1/50	900	1350	310
	STARLET 18	mm 1600	12	16	18	-14 -18	230/1/50	900	1500	380
	STARLET 24	mm 2100	12	16	24	-14 -18	230/1/50	1400	2000	470
pasticcera pastry	STARLET 1100	mm 1100	6	12		+2 +8	230/1/50	800	900	280
	STARLET 1600	mm 1600	10	14		+2 +8	230/1/50	1400	1500	350
	STARLET 2100	mm 2100	10	16		+2 +8	230/1/50	1600	1800	440
pralineria chocolate	STARLET 1100	mm 1100				+14 +18	230/1/50	500	750	280
	STARLET 1600	mm 1600				+14 +18	230/1/50	500	800	350
tavola calda secca dry heat cabinet	STARLET 1100	mm 1100				+40 +80	230/1/50		900	280
	STARLET 1600	mm 1600				+40 +80	230/1/50		1300	350

\*Quota esclusi i fianchi terminali (2 fianchi terminali + 32mm) Dimensions exclude end sides (2 end sides add 32mm)

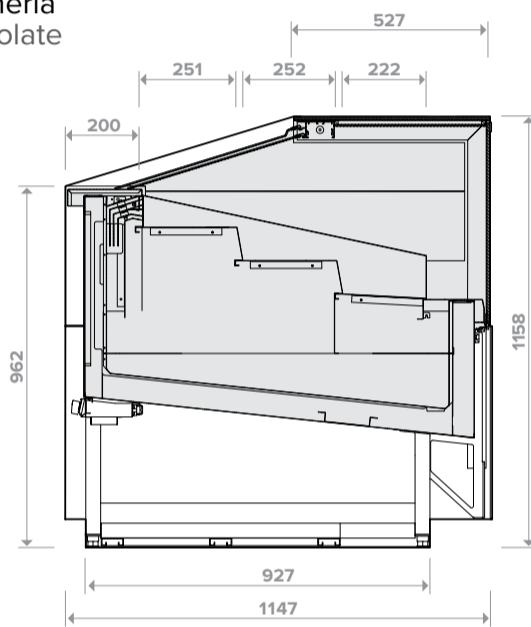
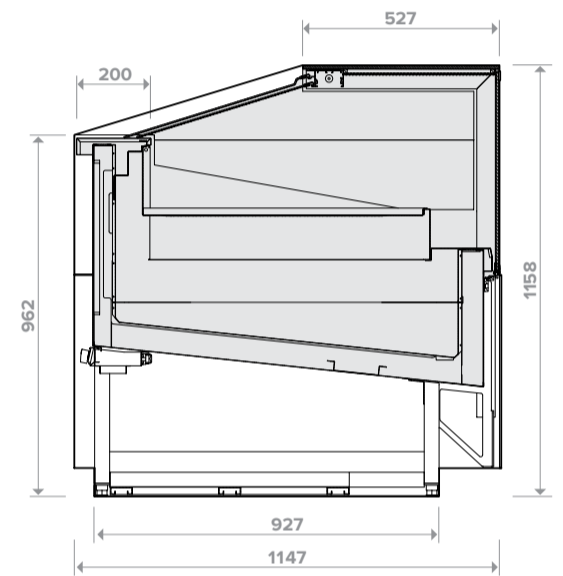
**DeBlasi**



De Blasi Spa - Via Avogadro, 3 - 61032 Fano (PU)  
tel +39 0721/86971 - fax +39 0721/869385  
www.deblasi.it

Art and Copy / 3D Pictures Acanto Comunicazione  
Photolithographs Olimpia Visual Plan  
Print Gapho5

I colori, le tonalità e le finiture dei prodotti contenuti in questo catalogo possono presentare sensibili variazioni dall'originale a causa dei limiti grafici e di stampa. De Blasi Spa si riserva di apportare modifiche tecniche e funzionali ove ritenesse necessario al fine di migliorare i propri prodotti e la soddisfazione del cliente. Due to graphical and printing limitations, colours, shades and finishes of all products shown in this catalogue can present visible variations compared to the original ones. De Blasi Spa reserves the right to introduce technical and functional changes where deemed necessary in order to improve its own products and its clients' satisfaction.